



It All Adds up to Zero

California's Zero Net Energy Future (and What We're Doing About it)



Bay REN Forum
October 24, 2017

Rory Cox, Analyst, Energy Efficiency Branch



What is Zero Net Energy?

CA Department of General Services Definitions

- **ZNE building** – An energy-efficient building where, on a source energy basis, the actual annual consumed energy is less than or equal to the on-site renewable generated energy.
- **ZNE campus** – An energy-efficient campus where, on a source energy basis, the actual annual consumed energy is less than or equal to the on-site renewable generated energy.
- **ZNE portfolio** – An energy-efficient portfolio in which, on a source energy basis, the actual annual consumed energy is less than or equal to the on-site renewable generated energy.
- **ZNE community** – An energy-efficient community where, on a source energy basis, the actual annual consumed energy is less than or equal to the on-site renewable generated energy.





California's ZNE Building Goals

All new
residential
construction in
California will be
ZNE by 2020

All new
commercial
construction will be
ZNE
by 2030

Legislation!
SB 350
AB 32/SB 32
AB 793/AB 758
AB 802
...

50% of existing
commercial
buildings will be
retrofit to ZNE by
2030

All new &
major renovations
of **state** buildings
shall be ZNE 2025;
50% at 2020



CA Policies Have Catalysed the Market

- Production Builders Envision, Meritage, DeYoung, Pulte all developing ZNE residential communities
- Local Governments with ZNE policies and codes
 - Lancaster – Solar Roofs
 - Palo Alto – ZNE Policy
 - Santa Monica – ZNE Policy
 - Hayward – ZNE public buildings
 - Sonoma and Marin CCAs
 - San Diego
- 4 And more....

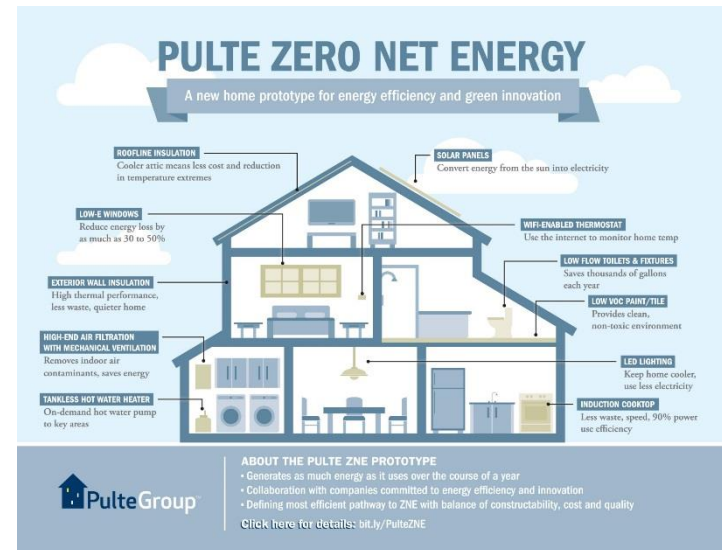

Net Zero Newhall



A National Model for Sustainability

Newhall Ranch will set a new standard for sustainability through a comprehensive array of green innovations onsite and within L.A. County, as well as funding direct emissions reduction activities locally, in California, and around the world. From green buildings that encourage energy efficiency to a robust transportation management program, Newhall Ranch will create a model for living and working sustainably in California.



Upholding Green Building & Design Standards

- ✓ Innovative energy efficiency measures and renewable energy generation (e.g., solar power) to design homes, commercial buildings and public facilities to meet Zero Net Energy standards within Newhall Ranch.

Show your support

Sign up to stay informed



ZNE is Growing...

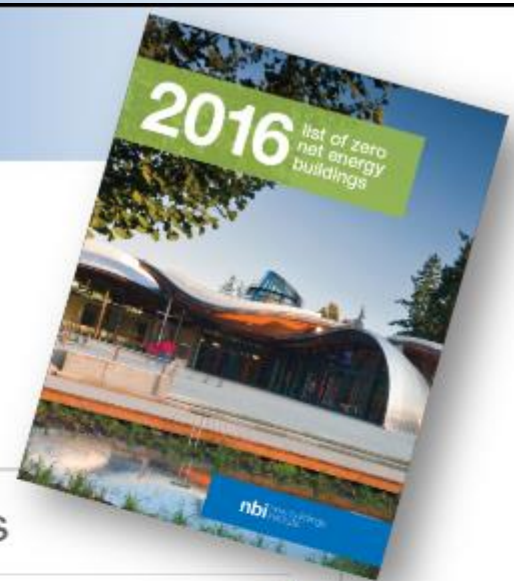

Growth of ZNE and Ultra-Low Energy Buildings

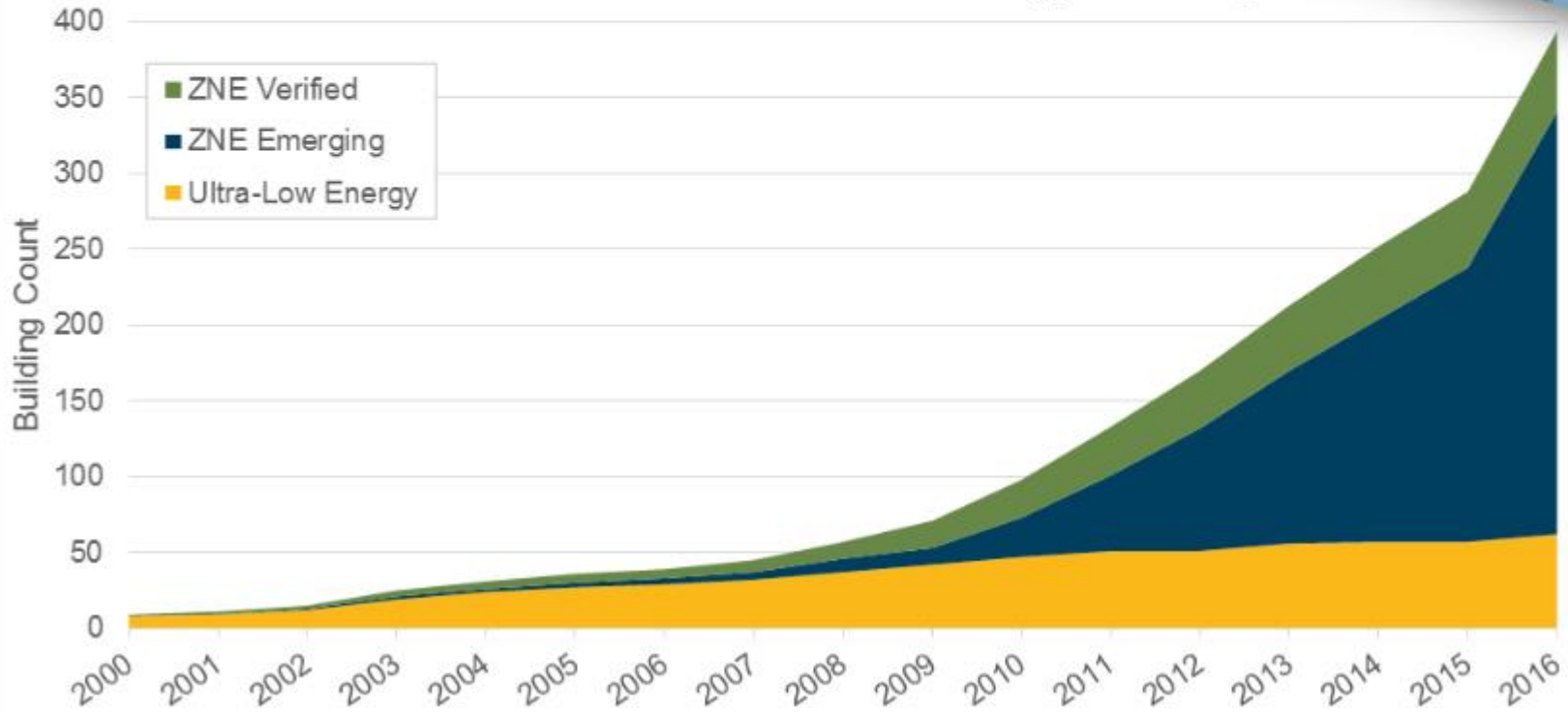

5 Source: New Building Institute (national data)





CPUC's Role in Zero Net Energy

- Long-Term Energy Efficiency Strategic Plan
 - New Residential ZNE Action Plan
 - Working with CEC on meeting SB 350 + other goals
- Oversee and direct funds for IOU's new construction and key energy efficiency programs
 - California Advance Home Program (Res. New Construction)
 - Savings By Design (Commercial New Construction)
 - Emerging Technologies
 - EM&V Studies on Market, Feasibility and Costs for ZNE
 - Codes Programs
- Leading State Policy Maker/Advocate for ZNE



2019 Standards Goals – Path to the Future



1. Increase building energy efficiency cost effectively
2. For Part 6, make **progress toward the ZNE** goal as possible within the **confines of NEM and life cycle costing rules**, while recognizing that Part 6 is an important but not the only tool for achieving ZNE
3. Contribute to the State's GHG reduction goals
4. **Promote self-utilization of the PV generation** by encouraging or requiring **demand flexibility and grid harmonization strategies**
5. Provide **independent compliance path** for both mixed-fuel and all electric homes
6. Achieve the above goals while ensuring real benefits for the building occupants with **positive benefit to cost ratios** for all efficiency and generation measures
7. Provide the tools for local governments to adopt **ordinances to achieve ZNE through Part 11 Reach Codes**, and other beyond code practices

The proposed 2019 Standards strategy will accomplish all seven goals listed above



Builds on Commission's Energy Design Rating Tool



- Energy Design Rating (EDR) score show how close a home is to the ZNE target
 - Aligned with RESNET
 - Reference home is a 2006 IECC compliant home, EDR=100
 - A score of zero means the house is a ZNE building
- CEC's CBEECC-Res software has the capability to calculate EDR scores for EE and PV
- Builders can use a combination of envelope energy efficiency features, better appliances, PVs, and other strategies to get to the target EDR

Download CBEECC-Res here for free:

<http://www.bwilcox.com/BEES/BEES.html>

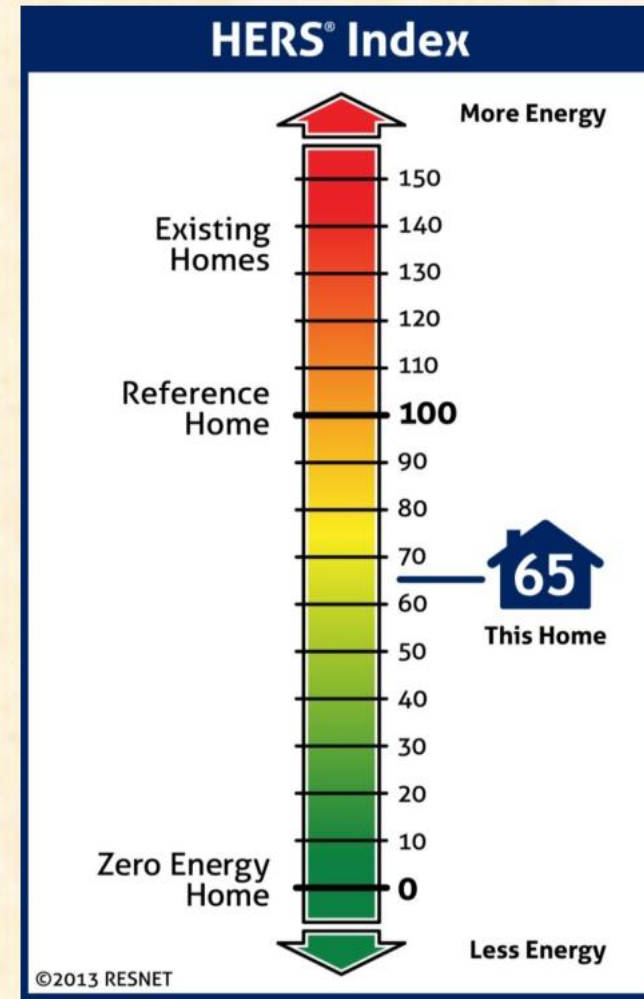

Energy Design Rating Dashboard

2019_CZ12_2700ft2 - v30 12 S27 G20 M01

Compliance Summary | **Energy Design Rating** | Energy Use Details

EDR of Proposed Efficiency: **41.9** - EDR of Prop PV + Flexibility: **19.1** = Final Proposed EDR: **22.8**
 EDR of Standard Efficiency: **43.2** - EDR of Minimum Required PV: **18.5** = Final Std Design EDR: **24.7**

End Use	Reference Design Site (kWh)	Reference Design Site (therms)	Reference Design (kTDV/ft ² -yr)	Proposed Design Site (kWh)	Proposed Design Site (therms)	Proposed Design (kTDV/ft ² -yr)	Design Rating Margin (kTDV/ft ² -yr)
Space Heating	584	486.0	45.09	187	217.2	19.51	25.58
Space Cooling	1,729		59.71	317		17.22	42.49
IAQ Ventilation	194		1.99	194		1.99	0.00
Other HVAC			0.00			0.00	0.00
Water Heating		176.3	13.03		119.9	8.86	4.17
Photovoltaics				-5,022		-43.51	43.51
Battery						0.00	0.00
Inside Lighting	2,615		30.42	616		6.98	23.44
Appl. & Cooking	989	73.4	15.65	1,040	45.1	14.46	1.19
Plug Loads	3,267		35.06	2,371		25.03	10.03
Exterior	328		3.54	152		1.61	1.93
TOTAL	9,705	735.7	204.49	-146	382.3	52.15	152.34

Done



CPUC's Grid Integration Study

- CEC is currently developing a ZNE residential building code
- CPUC managing study by DNV-GL regarding socialized cost, “ZNE Grid Integration Study”
- Purpose: Evaluate the impacts of ZNE on the distribution grid to be included in Title 24 cost-effectiveness method
- Scope: DNV GL's scope is to calculate the integration costs of ZNE to the grid and work with CEC to incorporate these costs into Title 24.





DNV-GL Methodology

- **Mapped annual PV growth** to distribution circuits, using a geographic allocation method.
- Assumed **2kW system size** per home
- Categorized into **representative circuits**
- Performed flow studies on **75 sample circuits** assuming up to 160% penetration
- Evaluated **technical criteria**: voltage, thermal, reverse power flow
- Added **mitigation measures**: traditional measures, energy storage, smart inverters, optimal location
- Examined 2 scenarios:
 - **High Cost case** - all ZNE homes lumped together in one place
 - **Low Cost case** – ZNE homes distributed throughout feeder

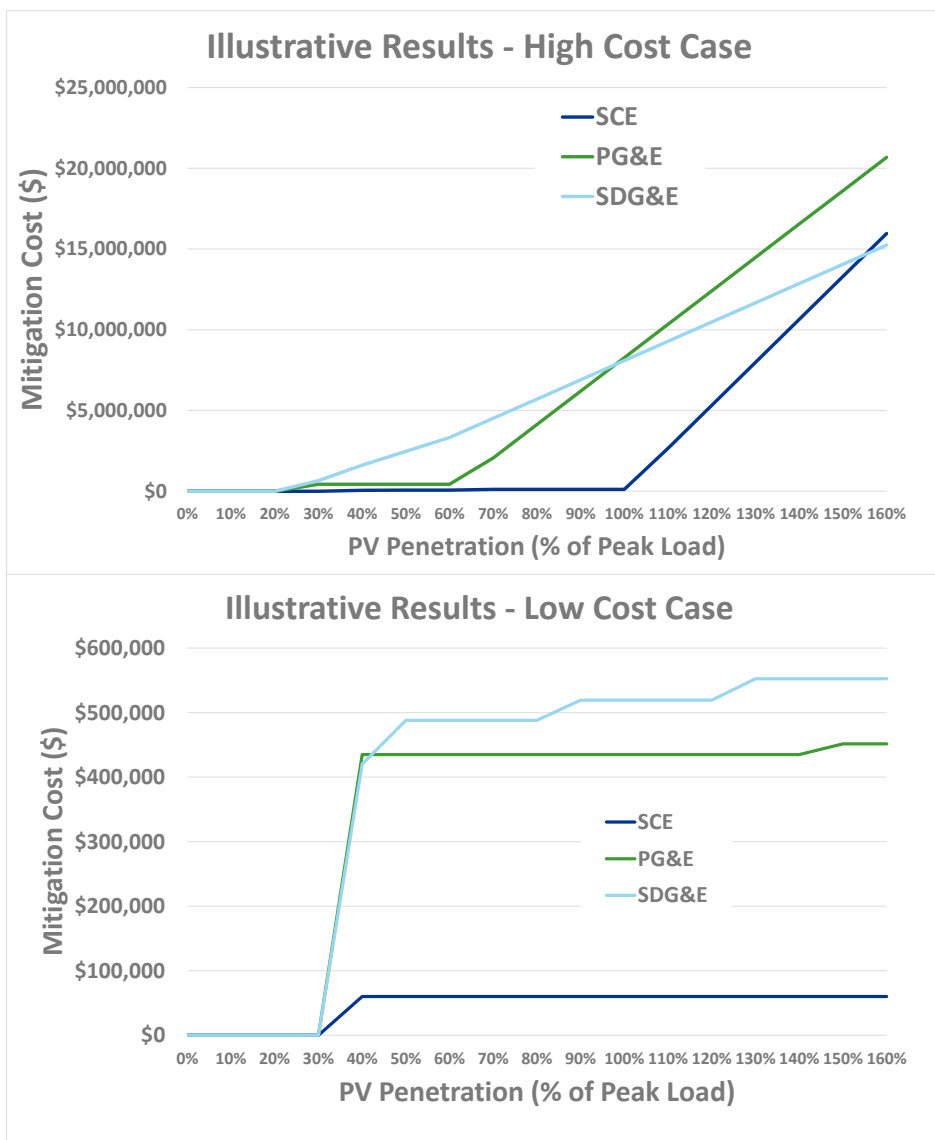



Results: High Cost Scenario

Grid Integration Costs for new PV between 2016 and 2026

High Cost Case	PG&E		SCE		SDG&E	
	Total Cost	Cost Per Ratepayer	Total Cost	Cost Per Ratepayer	Total Cost	Cost Per Ratepayer
Without ZNE	\$850 M	\$157	\$134 M	\$27	\$605 M	\$432
With ZNE	\$1,473 M	\$273	\$179 M	\$36	\$698 M	\$498
Difference	\$623 M	\$116	\$45 M	\$9	\$93 M	\$66



Smart Inverter Sensitivity Case

- Use of smart inverter functions (i.e., Volt / Var control) as mitigation measure
- Assumptions:
 - Used IOUs' Volt / Var curves
 - **Reactive power priority** assumed.
 - Where smart inverters absorbed reactive power, a **capacitor bank** was assumed to be installed on the feeder. Functionality is assumed autonomous, so **no other costs were added**.
 - **Real power losses not been included** (max loss is 5% at any time; total energy loss would be significantly lower than this).
- Affects **high cost case only**. The low cost case results remain the same, as there was no requirement for energy storage to mitigate problems in that case.

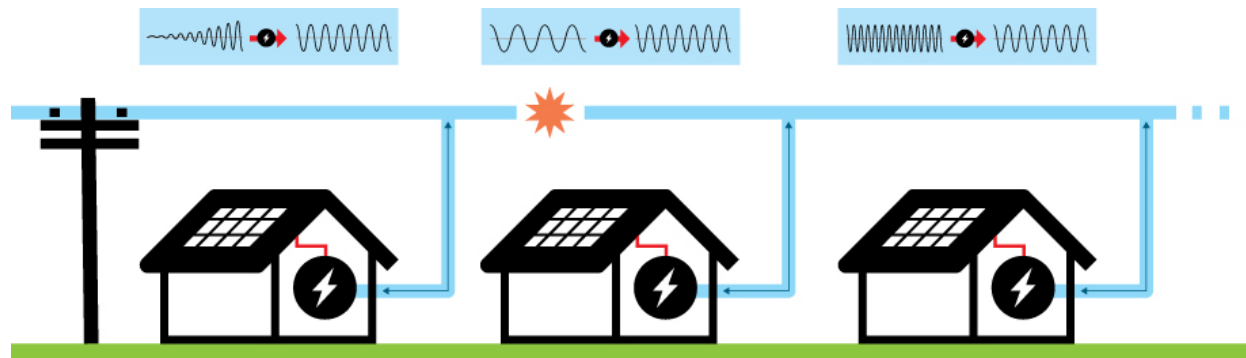



Results: Smart Inverter Sensitivity Case

Grid Integration Costs for new PV between 2016 and 2026

Smart Inverter Study	PG&E		SCE		SDG&E	
	Total Cost	Cost Per Ratepayer	Total Cost	Cost Per Ratepayer	Total Cost	Cost Per Ratepayer
Without ZNE	\$262 M	\$48	\$92 M	\$18	\$252 M	\$180
With ZNE	\$510 M	\$94	\$116 M	\$23	\$289 M	\$206
Difference	\$248 M	\$46	\$24 M	\$5	\$36 M	\$26

1/3 to 2/3 lower than High Cost Scenario



Results: Low Cost Scenario

Grid Integration Costs for new PV between 2016 and 2026

Low Cost Case	PG&E		SCE		SDG&E	
	Total Cost	Cost Per Ratepayer	Total Cost	Cost Per Ratepayer	Total Cost	Cost Per Ratepayer
Without ZNE	\$75 M	\$14	\$51 M	\$10	\$38 M	\$27
With ZNE	\$117 M	\$21	\$36 M	\$7	\$43 M	\$31
Difference	\$42 M	\$7	\$15 M	\$3	\$6 M	\$4

80% – 95% lower than High Cost Scenario



Mitigation Measures and Assumed Costs

Technical Limit	Mitigation Measure	Cost
Voltage	New voltage regulator	\$150,000
Voltage (if not mitigated by voltage regulator)	Energy storage	\$460/kW + \$450/kWh + \$1500/100kW for installation. Assume 4 hours of storage required
Thermal Loading	Re-conductoring	\$190/ft (average of overhead and underground re-conductoring costs)
Reverse Power Flow at Regulator	Enable co-generation mode	\$60,000
Reverse Power Flow at Substation Transformer	Enable co-generation mode	\$60,000
Reverse Power Flow at Re-Closer	Implement re-close blocking	\$145,000



Reasons for the Cost Differences

- Average PV penetration
 - PG&E has the highest
- Number of homes projected per feeder
 - PG&E has the highest home : feeder ratio
- Distance from substation to end of circuit. Longer circuits are more sensitive to voltage issues
 - PG&E circuits are generally the longest

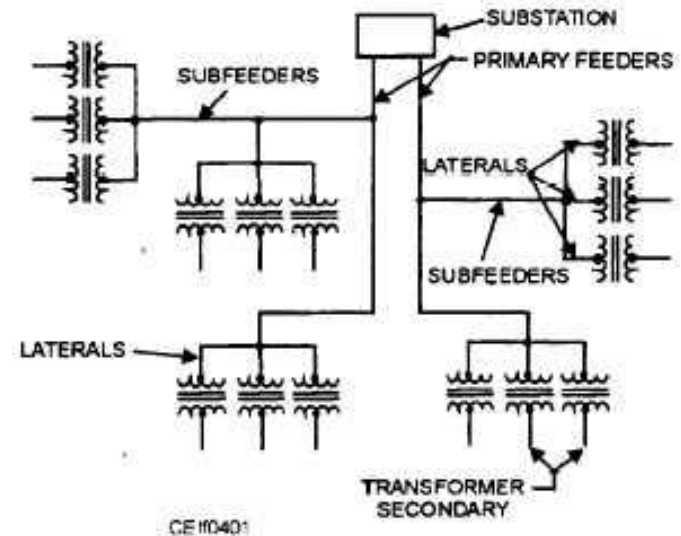

Image: Integrated Publishing



Staff Conclusions

- **Integration costs** of high penetration PV – whether driven by ZNE policy or NEM policy alone – **can be high if not mitigated.**
- **Mitigation measures are available** to reduce grid upgrade costs to more acceptable levels
 - **Smart inverters:** CPUC should update required smart inverter settings.
 - **Optimal location:** IOUs Integration Cost Analysis (ICA) tool should be helpful to indicate low cost locations.
- **Most likely case** is probably in the range indicated by the Smart Inverter Sensitivity Case
 - Effective Sept 2017 : Smart Inverter Phase 1 capabilities will be required
 - CPUC staff proposal to modify Rule 21 to require reactive power priority (in Volt / Var settings)
 - Debatable whether realistic to assume that PV will be installed throughout a circuit



Questions?

Rory Cox, Senior Analyst
California Public Utilities Commission –
Energy Division

rory.cox@cpuc.ca.gov

415-703-1093